

## ISO 7379 : Hexagon Socket Head Shoulder Screws

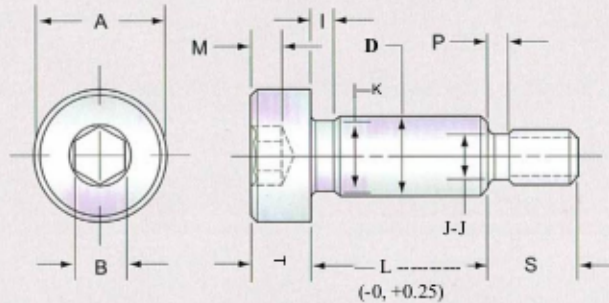

Dimensions (mm)

Nom. Size	A	H	D	B	M min.	S
M6	9.78- 10.22	4.32- 4.50	5.951 - 5.987	3.020 - 3.080	2.40	9.25- 9.75
M6.5	9.78- 10.22	4.32- 4.50	6.451 - 6.487	3.020 - 3.080	2.40	9.25- 9.75
M8	12.73- 13.27	5.32- 5.50	7.951 - 7.987	4.020 - 4.095	3.30	10.75- 11.25
M10	15.73- 16.27	6.78- 7.00	9.951 - 9.987	5.020 - 5.095	4.20	12.75- 13.25
M12	17.73- 18.27	7.78- 8.00	11.941 - 11.984	6.020 - 6.095	4.90	15.60- 16.40
M13	17.73- 18.27	8.78- 9.00	12.941 - 12.984	6.020 - 6.095	4.90	15.60- 16.40
M16	23.67 - 24.33	10.73-11.00	15.941 - 15.984	8.025 - 8.115	6.60	17.60- 18.40
M20	29.67 - 30.33	13.73-14.00	19.928- 19.980	10.025 -10.115	8.80	21.60- 22.40
M25	35.61 - 36.39	15.73-16.00	24.928 - 24.980	12.032 -12.142	10.00	26.60 - 27.40

Nom. Size	K min.	J	l max.	P max.	R. S. Torque (NM)
M6	5.42	3.68- 3.86	2.50	2.00	5.6
M6.5	5.92	3.68- 3.86	2.50	2.00	5.6
M8	7.42	4.40- 4.58	2.50	2.50	9.6
M10	9.42	6.03- 6.25	2.50	3.10	25
M12	11.42	7.69- 7.91	2.50	3.70	51
M13	12.42	7.69- 7.91	2.50	3.70	51
M16	15.42	9.35- 9.57	2.50	4.40	92
M20	19.42	12.96-13.33	2.50	5.00	245
M25	24.42	16.30-16.57	3.00	6.30	485

### Mechanical Properties

Property Class	12.9
Hardness ( HRC )	39-44
Tensile Strength ( Mpa )	1100 min.
Decarburization and Carburization ( See Page 17 )	E = 3/4H1

### ■ Typical Application Fixture

Also called Stripper Bolts in the U.S. the shoulder on these parts allow them to be used in applications where mating parts need to be adjusted, slide, or pivot without removing the fastener.

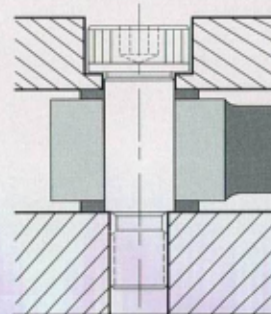

### Notes :

1. Surface Roughness : Ra 0.8 um max.
2. Thread Class : 5g6g for property class 12.9.
3. R. S. Torque = Recommended Seating Torque.
4. Working Temperature : -50°C ~ +300°C